

RIBAG

VIOR X

Montageanleitung
Instructions de montage
Istruzioni per il montaggio
Fitting instructions

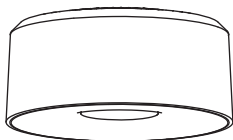

RIBAG Licht AG
Kanalstrasse 18, 5745 Safenwil, Switzerland
Service: Tel. +41 62 737 50 70, service@ribag.com

BT2324.01/05.24

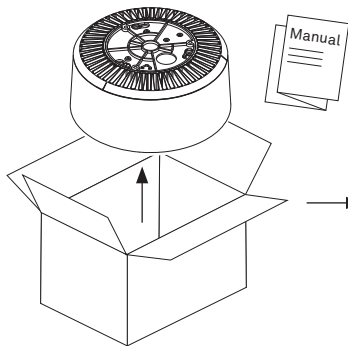

www.ribag.com/downloads

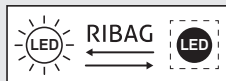

DE

Sie haben sich für ein zuverlässiges RIBAG-Markenprodukt entschieden. Bei fachgerechter Installation und sachgemässer Handhabung dürfen Sie sich lange Zeit daran freuen. Bitte beachten Sie die Montageanleitung und die örtlichen Installationsvorschriften.

Wichtig:

- Die Montage der Leuchten muss durch autorisiertes Personal erfolgen.
- Das Arbeiten an der Leuchte bei anliegender Spannung ist untersagt.
- Enthält eingebaute LED-Lampen, die durch den Hersteller austauschbar sind.
- Maximale Leistungsstufe der Lichtquelle, gem. Angaben auf den Leuchten, beachten und unbedingt einhalten. Nichtbeachtung kann zur Zerstörung der Lichtquelle führen.
- Für einen optimalen Betrieb der Leuchte ist eine regelmässige, vorsichtige Reinigung notwendig.

Für Artikel, die ohne unsere ausdrückliche Zustimmung verändert werden, entfällt jede Haftung.

Druckfehler und technische Änderungen vorbehalten.

FR

Vous avez fait votre choix en faveur d'un produit fiable de la marque RIBAG. Installé dans les règles de l'art et manipulé avec précaution, ce produit vous donnera entière satisfaction pendant très longtemps. Merci de suivre les consignes de montage et de respecter les prescriptions locales d'installation.

Important:

- Le montage des luminaires doit être effectué par personnel autorisé.
- Il est interdit de travailler sur le luminaire sous tension.
- Contient des lampes LED intégrées, qui peuvent être remplaçables par le fabricant.
- Tenir compte de la puissance maximale des luminaires indiquée et la respecter impérativement. Le non-respect de cette consigne peut entraîner la destruction des modules à LED.
- Un nettoyage régulier effectué avec précaution est indispensable pour assurer un fonctionnement optimal du luminaire.

Nous n'assumons également aucune responsabilité pour les articles qui subissent des modifications sans notre approbation expresse.

Sous réserve d'erreurs d'impression et de modifications techniques.

IT

Avete deciso di acquistare un prodotto affidabile della marca RIBAG. Rimarrete soddisfatti per molto tempo dell'installazione eseguita a regola d'arte e della messa in funzione adeguata. Vi preghiamo di prestare particolare attenzione alle istruzioni per il montaggio e alle disposizioni locali adottate in materia di installazione.

Importante:

- Il montaggio delle lampade deve essere eseguito da personale specializzato.
- È vietato lavorare alle lampade sotto tensione.
- Contiene lampade LED integrate, lampade sostituibili dal fabbricante.
- Osservare e rispettare rigorosamente il livello di potenza delle lampade, come indicato sulle luci stesse. In caso contrario i moduli LED possono andare distrutti.
- Per un funzionamento ottimale delle luci, è indispensabile una pulizia regolare e meticolosa.

Non ci assumiamo alcuna responsabilità per gli articoli modificati senza una nostra autorizzazione espressa.

Non si escludono errori di stampa e modifiche tecniche.

EN

You have purchased a reliable RIBAG brand product. Provided it is expertly installed and correctly operated you will enjoy its use for a very long time. Please observe the fitting instructions and the local installation regulations.

Important:

- The lamp must be fitted by qualified electrician personnel.
- Working on the lamp is prohibited if voltage is present / is only allowed under voltage-free conditions.
- Contains built-in LED lamps, that can be replaced by the manufacturer.
- Please observe and maintain the maximum power stage of the lamps as stated on the lighting unit. Otherwise, the LED modules may be destroyed.
- For optimum operation the lighting units should be regularly and carefully cleaned.

All liability is declined for items which have been modified without our express agreement.

We reserve the right to make any technical changes and disclaim any responsibility for possible printing error.

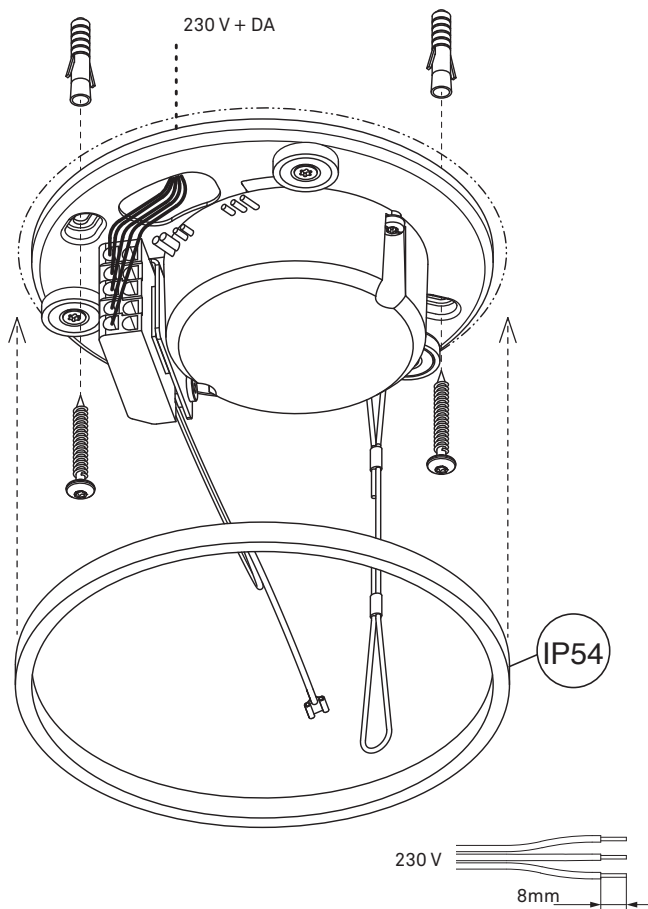
1**DE** Deckenanschluss 230 V, optional mit Dichtungsring (IP54)**FR** Raccordement au plafond 230 V, en option avec anneau d'étanchéité (IP54)**IT** Collegamento a soffitto 230 V, a scelta con anello di tenuta (IP54)**EN** Ceiling connection 230 V, optionally with sealing ring (IP54)

2

DE Montage/Demontage
FR Montage/Démontage
IT Montaggio/Smontaggio
EN Assembly/Dismantling

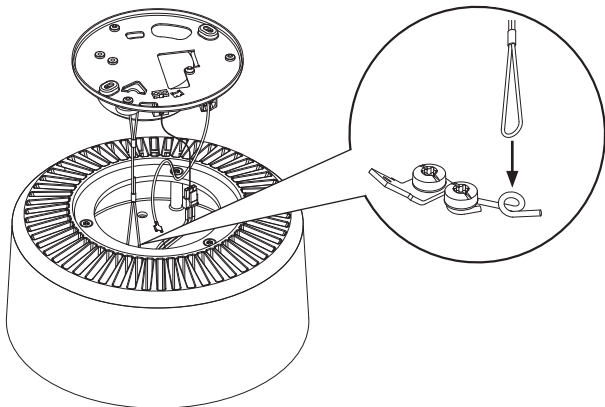
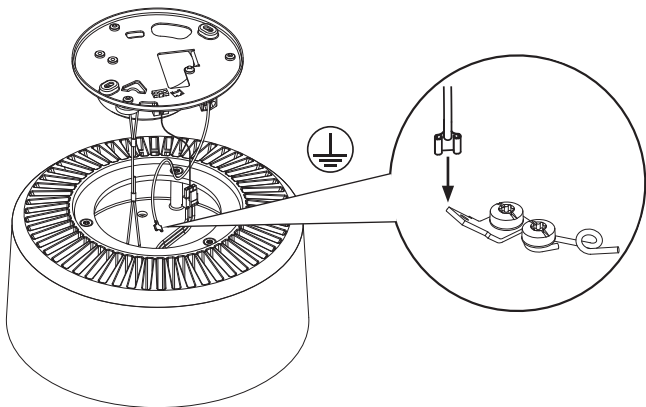
**3**

4

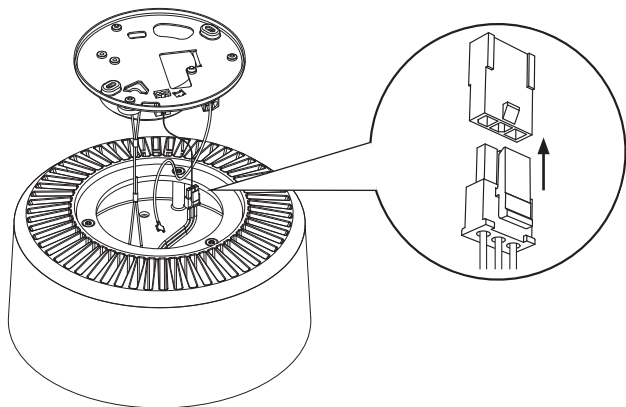

5

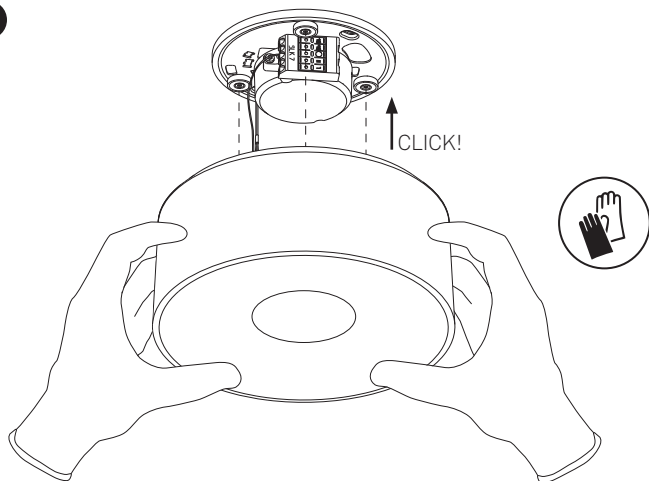

- DE** Anschlusschema für nicht dimmbare Leuchten
- FR** Schéma de branchement pour luminaires sans variateur
- IT** Schema di collegamento per lampade non dimmerabili
- EN** Connection scheme for non-dimmable lamps

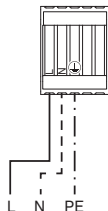

- DE** Schema für DALI-Betrieb, Anschlüsse polaritätsfrei (DT6/DT8)
- FR** Schéma pour le fonctionnement DALI Raccords sans polarité (DT6/DT8)
- IT** Schema per il funzionamento di DALI Collegamenti senza polarità (DT6/DT8)
- EN** Diagram for DALI operation Connections polarity-free (DT6/DT8)

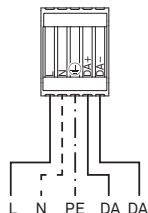

- DE** Schema für TouchDim-Betrieb Taster 2 sec. drücken
- FR** Schéma pour le fonctionnement TouchDim Appuyer sur le bouton-poussoir pendant 2 sec.
- IT** Schema per il funzionamento di TouchDim Premere il compasso per 2 secondi.
- EN** Diagram for TouchDim operation Press push-button for 2 sec.

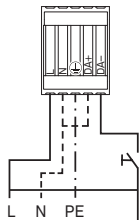

- DE** Anschlusschema für PhasenDim-Betrieb TRIAC
- FR** Schéma de branchement pour luminaires en mode PhaseDim TRIAC
- IT** Schema di collegamento per lampade in modalità dimmer a taglio di fase TRIAC
- EN** Connection scheme for PhaseCut operation TRIAC

